

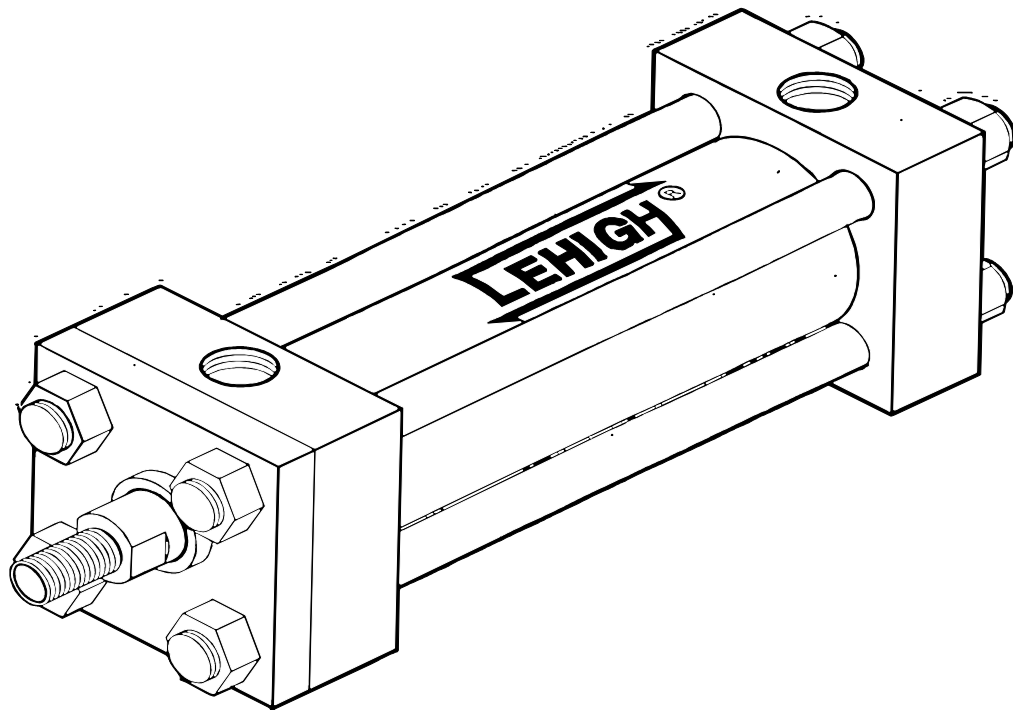

SERIES JHDH  
PRESSURE RATED HYDRAULIC CYLINDERS  
INSTALLATION & OPERATING INSTRUCTIONS



REMEMBER . . . .  
WHEN PERFORMANCE COUNTS  
SPECIFY LEHIGH

LEHIGH FLUID POWER, INC.  
1413 ROUTE 179  
LAMBERTVILLE, NJ 08530  
[sales@lehighfluidpower.com](mailto:sales@lehighfluidpower.com)  
609-397-3487 • FAX# 609-397-0932  
800-257-9515

ISSUE DATE 3/96  
Revised 2/98

**SERIES JHDH  
PRESSURE RATED HYDRAULIC CYLINDERS  
INSTALLATION AND OPERATING INSTRUCTIONS**

**LEHIGH FLUID POWER, INC.**  
1413 Route 179, Lambertville, NJ 08530  
**TEL: 800-257-9515**  
609-397-3487                      FAX: 609-397-0932

**TABLE OF CONTENTS**

	<b>Page</b>
.....	
A. Installation Instructions .....	1
B. Trouble Shooting Instructions .....	1 & 2
1. Jerky Action .....	1
2. Leakage .....	1 & 2
a. Loss of Power or No Power .....	1
b. Evident Leak at Rod Seal .....	2
c. Leak between the Cylinder Tube and End Caps (Heads) .....	2
3. Loud Metallic Impact Noise .....	2
C. General Overhaul Instructions .....	2 thru 4
1. General Guidelines .....	2 & 3
2. Piston & Rod Assembly .....	3
3. Final Assembly .....	3 & 4
D. Caution Section .....	4
List of Typical Repair Kit Contents .....	5
Component Torque Chart .....	6
Maximum Recommended Cylinder Operating Pressures .....	6
Figures 1, 2 and 3 .....	7 thru 9

**A. INSTALLATION:** (Follow Lockout/Tagout Procedures)

The cylinder is shipped from the factory with protective caps in the ports. Do not remove these caps until the piping is ready for installation. If the cylinder has been in storage for an extended period of time, it is advisable to exercise the cylinder, i.e., flex the internal seals by stroking the piston before installation. Insure the hydraulic lines are clean and equipped with suitable filters and pressure control.

Alignment of the piston rod with the work is necessary for the cylinder to operate satisfactorily and insure long life. Be sure all mounting surfaces are clean, smooth, flat and in alignment. Before finish piping of the cylinder, stroke the cylinder to check the mounting arrangement for misalignment or binding of attached mechanisms. The piston rod should extend and retract without any unsteady or jerky motion.

If the cylinder is equipped with cushions, adjust the cushion screws to produce the desired effect for the load, speed and line pressure to which the cylinder will be subjected under normal operating conditions.

**CAUTION:** Remember, cylinder cushions are intended to stop the cylinder mass and very light loads. If larger masses are involved, consider the use of shock absorbers or other load/mass stopping devices.

**B. TROUBLE SHOOTING:** (Follow Lockout/Tagout Procedures)

1. JERKY ACTION:

Check for misalignment, look for a bent or scored piston rod. The rod bushing may be damaged. Check the cylinder tube for the effect of external damage. Confirm that the cylinder supply pressure and volume are adequate to operate the cylinder under normal conditions.

2. LEAKAGE:

a. Loss of Power or No Power:

1. Check the line pressure at the machine. Check the operating pressure at the control valve for the cylinder and check the line pressure at the cylinder port(s).
2. Carefully apply pressure to one port of the cylinder and check for oil escaping from the opposite port or the exhaust port of the control valve.

**CAUTION:** This procedure requires experienced personnel with the knowledge to operate/test a cylinder with open lines/ports.

3. Excessive oil coming from the port(s) may indicate worn or damaged piston seals or a damaged cylinder tube. Both should be replaced in order for the cylinder to develop full power.

b. Evident Leak at Rod Seal:

The rod bushing assembly may normally be replaced without disassembly of the cylinder. Loosen and remove the “ED” (for rod bushing) locking screw if present. Using a close fitting wrench remove the rod bushing assembly from the cylinder by turning counter-clockwise (Figures 2 and 3).

Check the rod seal and wiper conditions and replace as required. The seals are found in their respective grooves in the bushing and head counterbore (Figure 3).

c. Leak between the Cylinder Tube and End Caps (Heads):

Tighten the tie rod nuts to the torque specified in the table that follows: Be sure the Open and Closed Heads are properly squared to each other. Check for the cylinder tube being seated in the tube groove in the face of each head. Continued leakage indicates a damaged or extruded tube end cover o-ring which may require replacement (Figure 3).

3. LOUD METALLIC IMPACT NOISE—Reference Figure 3:

(Follow Lockout/Tagout Procedures)

Check the cushion adjustment. To increase the cushioning effect turn the cushion screw clockwise (facing the screw driver slot in the cushion screw). If adjusting the cushion screw does not correct the problem, check for proper seating of the ball check ball (if one is supplied) or the end cap cushion ring may require replacement. Also, confirm the pressure and operation of externally mounted shock absorbers on the equipment prior to the replacement of the cushion ring, or consider the addition of external devices.

When replacing the end cap cushion ring, check the piston for impact damage. If the piston, piston rod, or rod end shows damage, check the mechanism adjustment instructions in the machine manual before returning the cylinder to operation.

**C. GENERAL OVERHAUL INSTRUCTIONS:** (Follow Lockout/Tagout

Procedures)

1. GENERAL GUIDELINES:

Remove the cylinder from the equipment and disassemble on a bench or other clean flat surface.

All necessary seal parts and the bushing for the overhaul are contained in the Cylinder Repair Kit. Additional repair parts required as a result of visual inspection may be required (piston rod, tube, etc.).

Clean and inspect all metal parts, particularly the piston rod, for wear, scratches or pitting. Replace the piston rod if its condition would damage the rod bushing or seals. Also check the tube I.D. Replace the tube if its condition would damage the piston or piston seals.

Inspect the piston to piston rod assembly. Is the piston secure on the piston rod? The piston nut tight? If in question proceed to the CAUTION SECTION of the Piston and Rod Assembly below before continuing with the repair.

## 2. PISTON & ROD ASSEMBLY—Reference Figure 1:

After carefully removing the old piston seals so as not to scratch, nick or burr the lip or groove of the piston, gently stretch/place the new piston seals into the piston grooves. Be sure that the flat sides of the seals are positioned towards the center of the piston.

Using a suitable lubricant compatible with both the seal material(s) and the hydraulic system, lubricate the piston seals, end cover o-rings and the “mouth” of the tube to ease reassembly.

## 3. FINAL ASSEMBLY:

Place the Closed Head (Cap End or Back Cover) on a flat surface with the tube grooved side up. Check that the tube o-rings are properly installed in the o-ring groove cavity and lubricated before proceeding. Position the tube in the tube groove and seat it against the bottom. Now lubricate the open “mouth” and carefully slip the piston and rod assembly into the tube. Be sure that the seal lips enter the tube without wrinkling, tearing or pinching.

NOTE: On larger bore and longer stroke cylinders, the assembly may have to be completed in the horizontal position.

Place the Open Head (Rod End or Front Cover) over the piston rod being sure that the tube grooved side is down. Check that the tube o-ring is properly installed in the o-ring groove cavity and lubricated, before proceeding. Set the tube groove over the tube and seat the tube into the groove.

Carefully install the rod bushing seals into their cavities (and the o-rings and backups, if supplied in the Repair Kit).

Carefully place the bushing over the rod threads and down the piston rod and into the bushing counterbore in Open Head. Watch to insure the rod seals and bushing o-ring

are not damaged during installation. Place the bushing flange on the Open Head such that it is properly positioned relative to the port in the Open Head and the configuration of the particular cylinder being repaired (Figure 3).

Check the position of the port in the Closed Head relative to the port position in the Open Head. Insert the tie rods and just snug the tie rod nuts against the tie rod washers.

NOTE: A small amount of lubricant should be placed on the tie rod nut faces to assure proper tie rod torque values are obtained following.

Lay the cylinder in a horizontal position on a smooth flat surface, with the mounting points of the cylinder supported and square the Open Head to the Closed Head. Re-snug the tie rods as necessary.

Alternately (cross pattern style) tighten the tie rod nuts in even 1/3 steps to the torque listed in the following table. Confirm the head alignment after each torque step set. To prevent tie rod rotation during torquing, hold the tie rods with locking pliers within 1/2 inch of the respective head.

**D. CAUTION SECTION:** (Follow Lockout/Tagout Procedures)

Reference Figures 1, 2 and 3

If the piston rod connection has been loosened, both the piston and piston rod must be cleaned, degreased, and reassembled prior to using the Repair Kit.

On cylinders with locking piston rod nuts, the carefully cleaned piston rod and locking nut are assembled using LOCTITE LOCQUIC PRIMER N® and LOCTITE REMOVABLE THREAD LOCKER #242® (BLUE) per package directions.

On cylinders with non-locking piston nuts and double rod end piston rods the carefully cleaned piston, piston rod, and non-locking nut are assembled using LOCTITE LOCQUIC PRIMER N® and LOCTITE STUD LOCK® (RED) per package directions.

Remember to install the Cushion Boss o-ring and Cushion Boss, as applicable, and the Piston Rod o-ring prior to assembly and application of the LOCTITE® products. Do not allow the LOCTITE® products to come in contact with the o-rings.

**ANY DEVIATION FROM THE LOCTITE® PRODUCT INSTRUCTIONS, ASSEMBLY PROCEDURE OR CONTAMINATION OF THE LOCTITE® PRODUCT MAY RESULT IN CATASTROPHIC FAILURE, EQUIPMENT DAMAGE, AND/OR PERSONAL INJURY.**

ALL LOCTITE® REFERENCED, TRADENAMED OR TRADEMARKED PRODUCTS ARE REGISTERED TO LOCTITE CORPORATION, ROCKYHILL, CT 06067 WITH APPLICATION AND USE SUPPORT AVAILABLE FROM YOUR LOCAL LOCTITE® DISTRIBUTOR.

## REPAIR KITS:

Repair kits containing all dynamic and static seals are available for all cylinders. These kits contain:

- 1 – Rod Bushing
- 1 – Rod Seal
- 1 – Rod Wiper
- 1 – Rod Bushing O-Ring
- 2 – Tube Seal O-Rings
- 2 – Piston Seals
- 2 – Cushion Screw O-Rings (use as required)
- 1 – Piston O-Ring (use as required)
- 1 – Cushion Boss O-Ring (use as required)

## TIE ROD TORQUE CHART

Bore Size	Piston Rod Diameter	Tie Rod Torque
1	ALL	38 Inch Pounds
1-1/2	ALL	96 Inch Pounds
2	ALL	168 Inch Pounds
2-1/2	ALL	168 Inch Pounds
3-1/4	ALL	29 Foot Pounds
4	ALL	29 Foot Pounds
5	ALL	58 Foot Pounds
6	ALL	58 Foot Pounds
8	ALL	85 Foot Pounds
10	ALL	130 Foot Pounds
12	ALL	130 Foot Pounds
14	ALL	200 Foot Pounds

### MAXIMUM RECOMMENDED CYLINDER OPERATING PRESSURE

1	ALL	1500 PSI
1-1/2	ALL	1500 PSI
2	ALL	1200 PSI
2-1/2	ALL	1000 PSI
3-1/4	ALL	1000 PSI
4	ALL	700 PSI
5	ALL	650 PSI
6	ALL	600 PSI
8	ALL	500 PSI
10	ALL	350 PSI
12	ALL	300 PSI
14	ALL	300 PSI

### BEARING RETAINER (SOCKET HEAD CAP SCREWS) TORQUE CHART

SHCS Size	Torque
NOTE: TORQUE VALUES LISTED ARE FOR LUBRICATED THREADS AND NUT FACES	
5/16-24	20 Foot Pounds
3/8-24	30 Foot Pounds
7/16-20	60 Foot Pounds
1/2-20	90 Foot Pounds



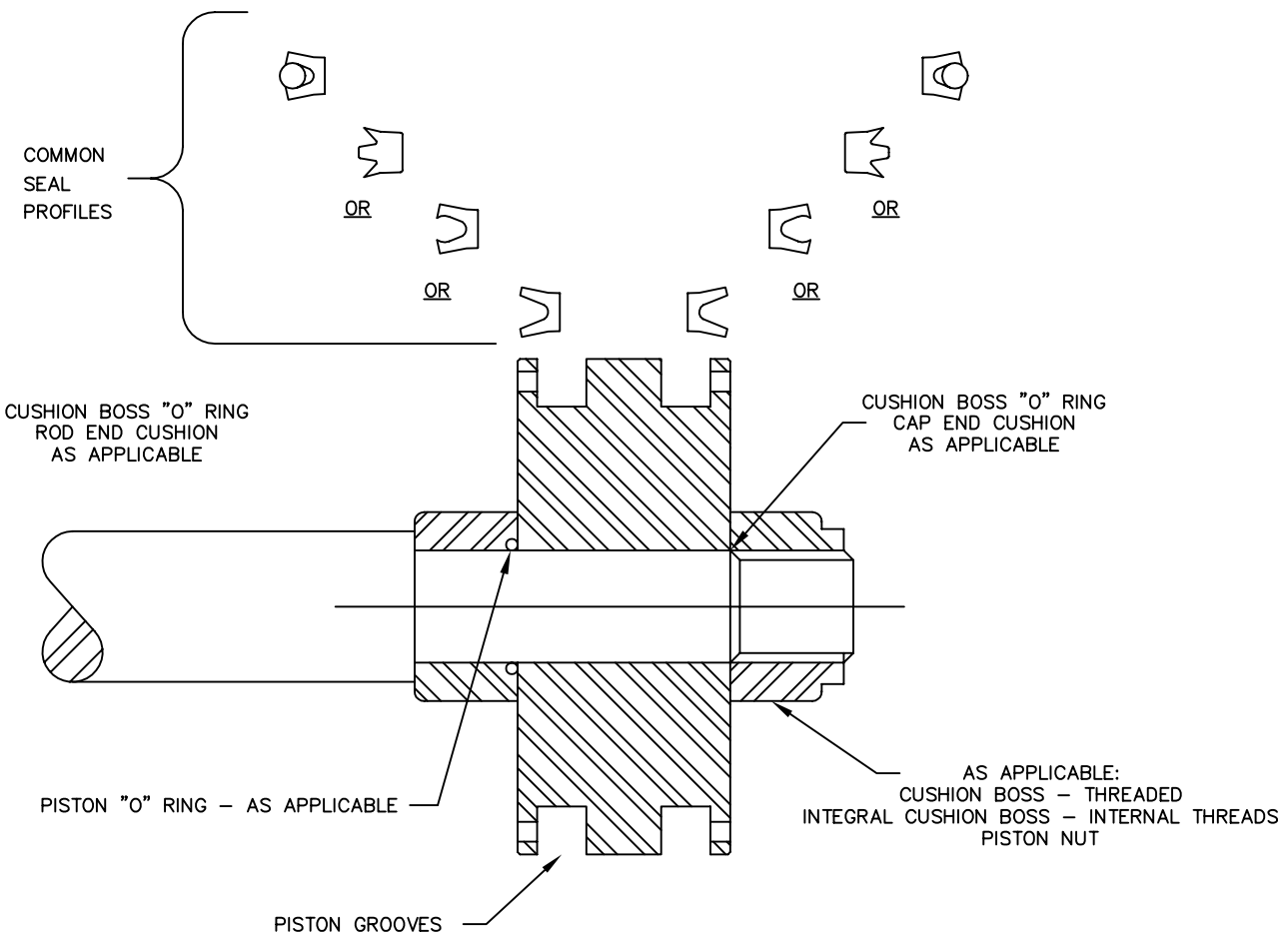

FIGURE NUMBER 1

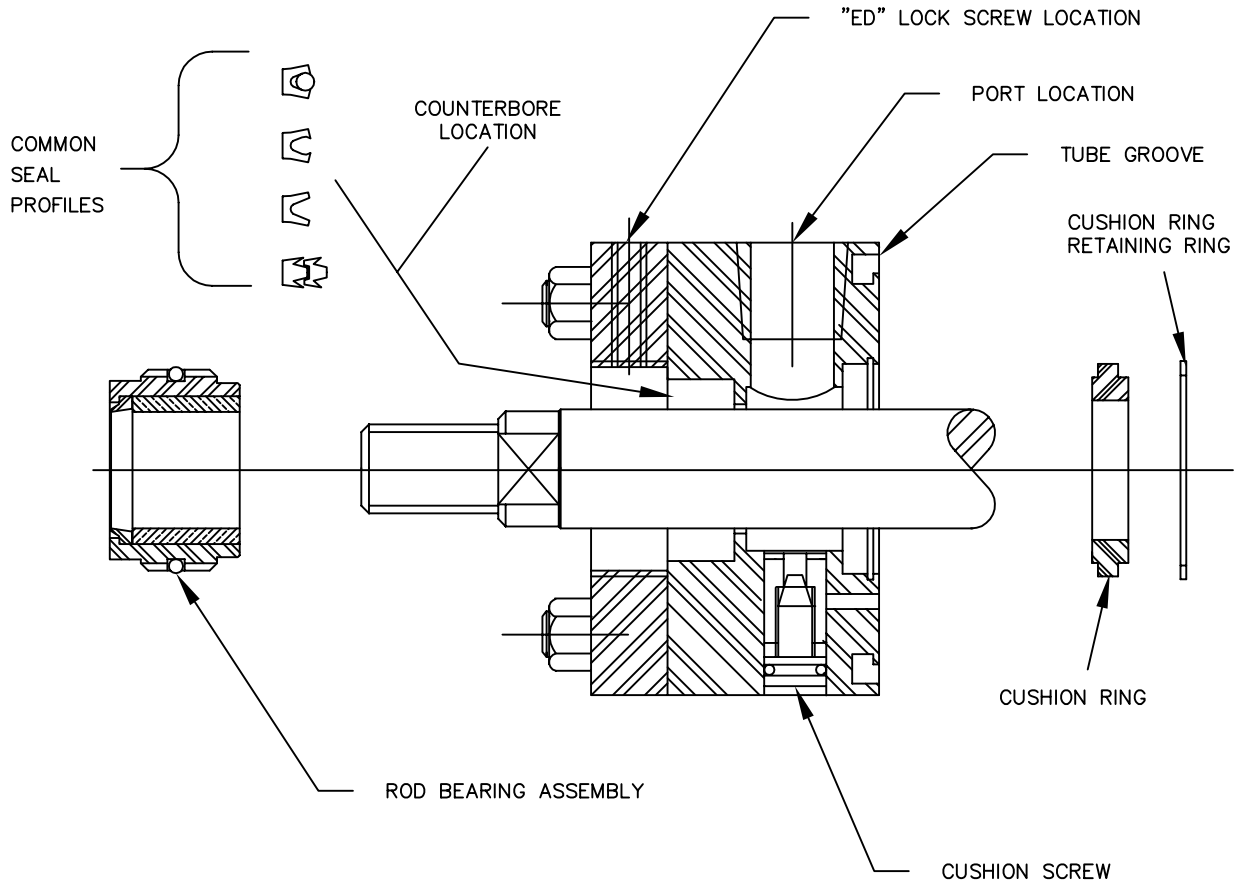

FIGURE NUMBER 2

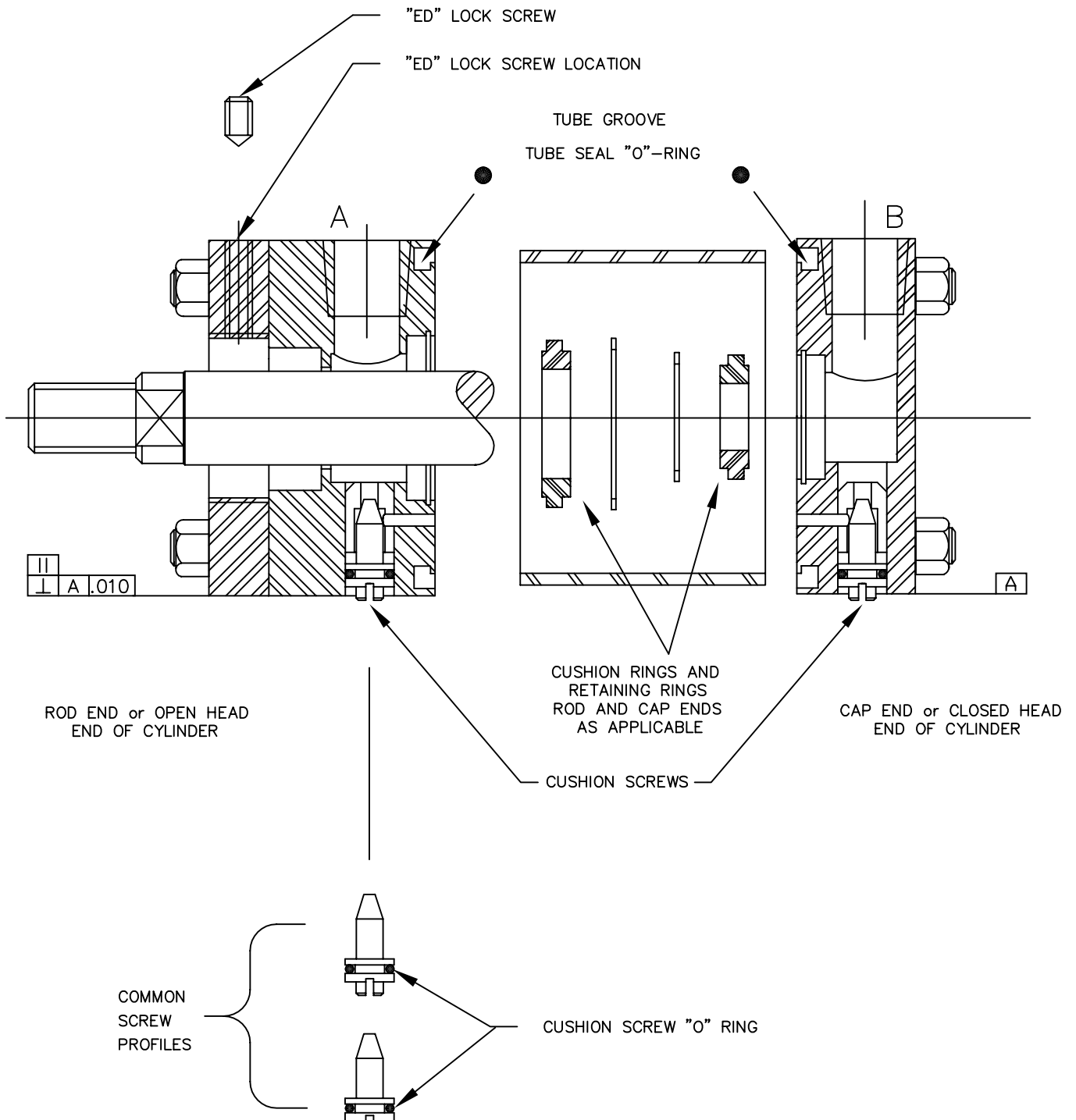

FIGURE NUMBER 3



LEHIGH FLUID POWER, INC.  
1413 ROUTE 179 • LAMBERTVILLE, NJ 08530  
609-397-3487 • FAX# 609-397-0932  
[sales@lehighfluidpower.com](mailto:sales@lehighfluidpower.com)

*For Toll Free Technical Support Call:*  
**800-257-9515**