

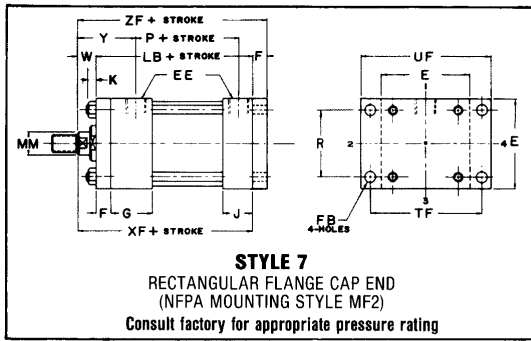

CAP END FLANGE MOUNTED CYLINDERS
1 1/2" to 8" BORE SERIES HP HIGH PRESSURE HYDRAULIC CYLINDERS

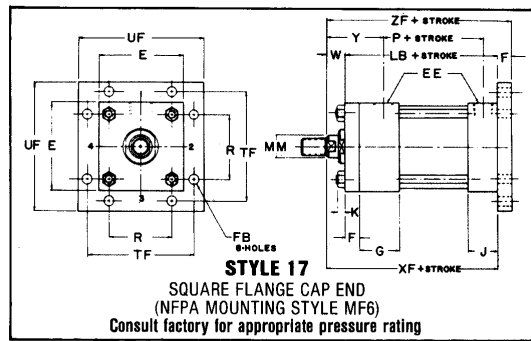

Standard Port location is Position 1.
 Standard Cushion location is Position 2.



Standard Port location is Position 1.
 Standard Cushion location is Position 2.

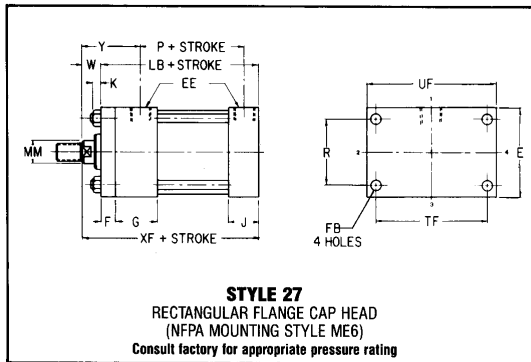

Standard Port location is Position 1. Standard Cushion location is Position 3.

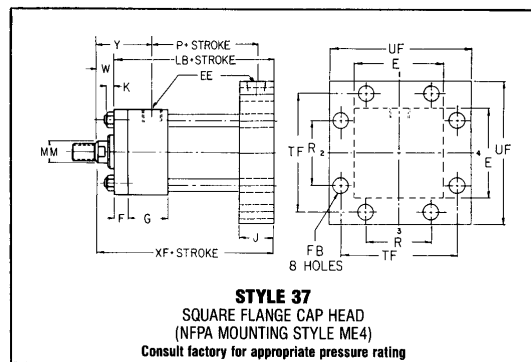

Standard Port location is Position 1. Standard Cushion location is Position 3.

Styles 6 and 7 particularly those above the 4" bore size, are not recommended for maximum operating pressures. For operating pressures above 1500 psi on the 5" and 6" bore cylinders, and 1000 psi on the 7" and 8" bore cylinders, we recommend the use of styles 16 and 17. Maximum operating pressure for 16 and 17 style flanges, in bores 5" thru 8", should not exceed 3000 psi. We recommend the use of high tensile mounting bolts on all flange mounted cylinders subjected to maximum pressure and shock loads.

ENVELOPE AND MOUNTING DIMENSIONS NOT AFFECTED BY ROD DIAMETER

BORE	E	EE		F	FB	G	J	K	R	TF	UF	LB	P
		NPTF	SAE									ADD STROKE	
1 1/2	2 1/2	1/2-14	10	3/8	7/16	1 3/4	1 1/2	3/8	1.63	3 7/16	4 1/4	5	2 7/8
2	3	1/2-14	10	5/8	9/16	1 3/4	1 1/2	7/16	2.05	4 1/8	5 1/8	5 1/4	2 7/8
2 1/2	3 1/2	1/2-14	10	5/8	9/16	1 3/4	1 1/2	7/16	2.55	4 5/8	5 5/8	5 3/8	3
3 1/4	4 1/2	3/4-14	12	3/4	11/16	2	1 3/4	9/16	3.25	5 7/8	7 1/8	6 1/4	3 1/2
4	5	3/4-14	12	7/8	11/16	2	1 3/4	9/16	3.82	6 3/8	7 5/8	6 5/8	3 3/4
5	6 1/2	3/4-14	12	7/8	15/16	2	1 3/4	3/4	4.95	8 3/16	9 3/4	7 1/8	4 1/4
6	7 1/2	1-11 1/2	16	1	1 1/16	2 1/4	2 1/4	7/8	5.73	9 7/16	11 1/4	8 3/8	4 7/8
7	8 1/2	1 1/4-11 1/2	20	1	1 3/16	2 3/4	2 3/4	1	6.58	10 5/8	12 5/8	9 1/2	5 3/8
8	9 1/2	1 1/2-11 1/2	24	1	1 5/16	3	3	1 1/16	7.50	11 13/16	14	10 1/2	6 1/8

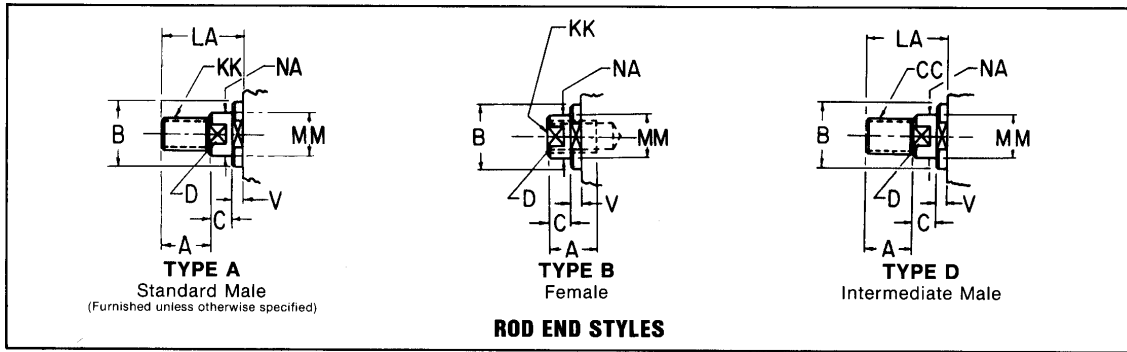

DIMENSIONS AFFECTED BY ROD DIAMETER

BORE	ROD DIA. MM	THREAD SIZE		ROD EXTENSIONS & PILOT DIMENSIONS							ENVELOPE DIMENSIONS				
		KK	CC	A	B	C	D	LA	NA	V	W	Y	XF	ZF	
		STD.			+.000/-0.002								ADD STROKE		
1 1/2	5/8	7/16-20	1/2-20	3/4	1.124	3/8	1/2	1 3/8	9/16	1/4	5/8	2	5 5/8	6	
	1*	3/4-16	7/8-14	1 1/8	1.499	1/2	7/8	2 1/8	15/16	1/2	1	2 3/8	6	6 3/8	
2	1	3/4-16	7/8-14	1 1/8	1.499	1/2	7/8	1 7/8	15/16	1/4	3/4	2 3/8	6	6 5/8	
	1 3/8*	1-14	1 1/4-12	1 5/8	1.499	5/8	1 1/8	2 5/8	1 5/16	3/8	1	2 5/8	6 1/4	6 7/8	
2 1/2	1	3/4-16	7/8-14	1 1/8	1.499	1/2	7/8	1 7/8	15/16	1/4	3/4	2 3/8	6 1/8	6 3/4	
	1 3/8	1-14	1 1/4-12	1 5/8	1.999	5/8	1 1/8	2 5/8	1 5/16	3/8	1	2 5/8	6 3/8	7	
	1 3/4*	1 1/4-12	1 1/2-12	2	2.374	3/4	1 1/2	3 1/4	1 11/16	1/2	1 1/4	2 7/8	6 5/8	7 1/4	
3 1/4	1 3/8	1-14	1 1/4-12	1 5/8	1.999	5/8	1 1/8	2 1/2	1 5/16	1/4	7/8	2 3/4	7 1/8	7 7/8	
	1 3/4	1 1/4-12	1 1/2-12	2	2.374	3/4	1 1/2	3 1/8	1 11/16	3/8	1 1/8	3	7 3/8	8 1/8	
	2	1 1/2-12	1 3/4-12	2 1/4	2.624	7/8	1 11/16	3 1/2	1 15/16	3/8	1 1/4	3 1/8	7 1/2	8 1/4	
4	1 3/4	1 1/4-12	1 1/2-12	2	2.374	3/4	1 1/2	3	1 11/16	1/4	1	3	7 5/8	8 1/2	
	2	1 1/2-12	1 3/4-12	2 1/4	2.624	7/8	1 11/16	3 3/8	1 15/16	1/4	1 1/8	3 1/8	7 3/4	8 5/8	
	2 1/2	1 7/8-12	2 1/4-12	3	3.124	1	2 1/16	4 3/8	2 7/16	3/8	1 3/8	3 3/8	8	8 7/8	
5	2	1 1/2-12	1 3/4-12	2 1/4	2.624	7/8	1 11/16	3 3/8	1 15/16	1/4	1 1/8	3 1/8	8 1/4	9 1/8	
	2 1/2	1 7/8-12	2 1/4-12	3	3.124	1	2 1/16	4 3/8	2 7/16	3/8	1 3/8	3 3/8	8 1/2	9 3/8	
	3	2 1/4-12	2 3/4-12	3 1/2	3.749	1	2 5/8	4 7/8	2 15/16	3/8	1 3/8	3 3/8	8 1/2	9 3/8	
	3 1/2	2 1/2-12	3 1/4-12	3 1/2	4.249	1	3	4 7/8	3 7/16	3/8	1 3/8	3 3/8	8 1/2	9 3/8	
6	2 1/2	1 7/8-12	2 1/4-12	3	3.124	1	2 1/16	4 1/4	2 7/16	1/4	1 1/4	3 1/2	9 5/8	10 5/8	
	3	2 1/4-12	2 3/4-12	3 1/2	3.749	1	2 5/8	4 3/4	2 15/16	1/4	1 1/4	3 1/2	9 5/8	10 5/8	
	3 1/2	2 1/2-12	3 1/4-12	3 1/2	4.249	1	3	4 3/4	3 7/16	1/4	1 1/4	3 1/2	9 5/8	10 5/8	
	4	3-12	3 3/4-12	4	4.749	1	3 3/8	5 1/4	3 15/16	1/4	1 1/4	3 1/2	9 5/8	10 5/8	
7	3	2 1/4-12	2 3/4-12	3 1/2	3.749	1	2 5/8	4 3/4	2 7/8	1/4	1 1/4	3 13/16	10 3/4	11 3/4	
	3 1/2	2 1/2-12	3 1/4-12	3 1/2	4.249	1	3	4 3/4	3 3/8	1/4	1 1/4	3 13/16	10 3/4	11 3/4	
	4	3-12	3 3/4-12	4	4.749	1	3 3/8	5 1/4	3 7/8	1/4	1 1/4	3 13/16	10 3/4	11 3/4	
	5	3 1/2-12	4 3/4-12	5	5.749	1	4 1/4	6 1/4	4 7/8	1/4	1 1/4	3 13/16	10 3/4	11 3/4	
8	3 1/2	2 1/2-12	3 1/4-12	3 1/2	4.249	1	3	4 3/4	3 3/8	1/4	1 1/4	3 15/16	11 3/4	12 3/4	
	4	3-12	3 3/4-12	4	4.749	1	3 3/8	5 1/4	3 7/8	1/4	1 1/4	3 15/16	11 3/4	12 3/4	
	5	3 1/2-12	4 3/4-12	5	5.749	1	4 1/4	6 1/4	4 7/8	1/4	1 1/4	3 15/16	11 3/4	12 3/4	
	5 1/2	4-12	5 1/4-12	5 1/2	6.249	1	4 5/8	6 3/4	5 3/8	1/4	1 1/4	3 15/16	11 3/4	12 3/4	

*Rod end cushions available only as non-adjustable type- Consult Lehigh