

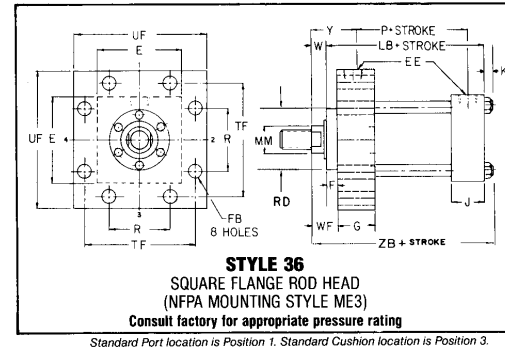

**ROD END FLANGE MOUNTED STAINLESS STEEL
1 1/2" TO 8" BORE, 3000 PSI RATED (MAXIMUM)
HIGH PRESSURE HYDRAULIC CYLINDERS**

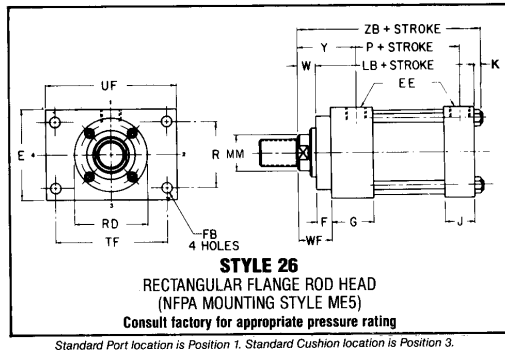
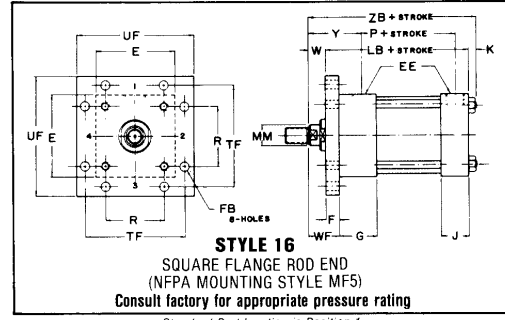
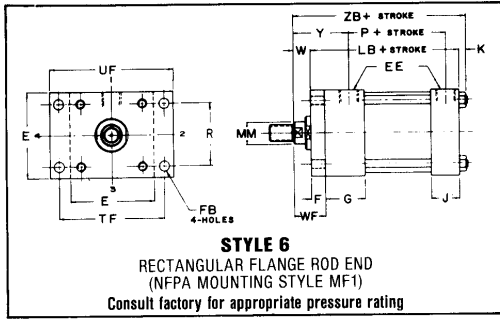

ENVELOPE AND MOUNTING DIMENSIONS NOT AFFECTED BY ROD DIAMETER

BORE	E	EE		F	FB	G	J	K	R	TF	UF	LB	P
		NPTF	SAE										
1 1/2	2 1/2	1/2-14	10	3/8	7/16	1 3/4	1 1/2	3/8	1.63	3 7/16	4 1/4	5	2 7/8
2	3	1/2-14	10	5/8	9/16	1 3/4	1 1/2	7/16	2.05	4 1/8	5 1/8	5 1/4	2 7/8
2 1/2	3 1/2	1/2-14	10	5/8	9/16	1 3/4	1 1/2	7/16	2.55	4 5/8	5 5/8	5 3/8	3
3 1/4	4 1/2	3/4-14	12	3/4	11/16	2	1 3/4	9/16	3.25	5 7/8	7 1/8	6 1/4	3 1/2
4	5	3/4-14	12	7/8	11/16	2	1 3/4	9/16	3.82	6 3/8	7 5/8	6 5/8	3 3/4
5	6 1/2	3/4-14	12	7/8	15/16	2	1 3/4	3/4	4.95	8 3/16	9 3/4	7 1/8	4 1/4
6	7 1/2	1-11 1/2	16	1	1 1/16	2 1/4	2 1/4	7/8	5.73	9 7/16	11 1/4	8 3/8	4 7/8
7	8 1/2	1 1/4-11 1/2	20	1	1 3/16	2 3/4	2 3/4	1	6.58	10 5/8	12 5/8	9 1/2	5 3/8
8	9 1/2	1 1/2-11 1/2	24	1	1 5/16	3	3	1 1/16	7.50	11 13/16	14	10 1/2	6 1/8

Styles 6 and 7 particularly those above the 4" bore size, are not recommended for maximum operating pressures. For operating pressures above 1500 psi on the 5" and 6" bore cylinders, and 1000 psi on the 7" and 8" bore cylinders, we recommend the use of styles 16 and 17. Maximum operating pressure for 16 and 17 style flanges, in bores 5" thru 8", should not exceed 3000 psi. We recommend the use of high tensile mounting bolts on all flange mounted cylinders subjected to maximum pressures and shock loads.

BORE	ROD DIA.	MOUNT STYLE	PORT POSITION	MAX. OPER. PRESSURE-PSI
5	3 1/2	26	1 or 3	2500
6	3 1/2	26	1 or 3	2500
	4	26	1 or 3	1500
7	4	26	1 or 3	2500
	5	26	1 or 3	1500
8	5	26	1 or 3	2500
	5 1/2	26	1 or 3	1500

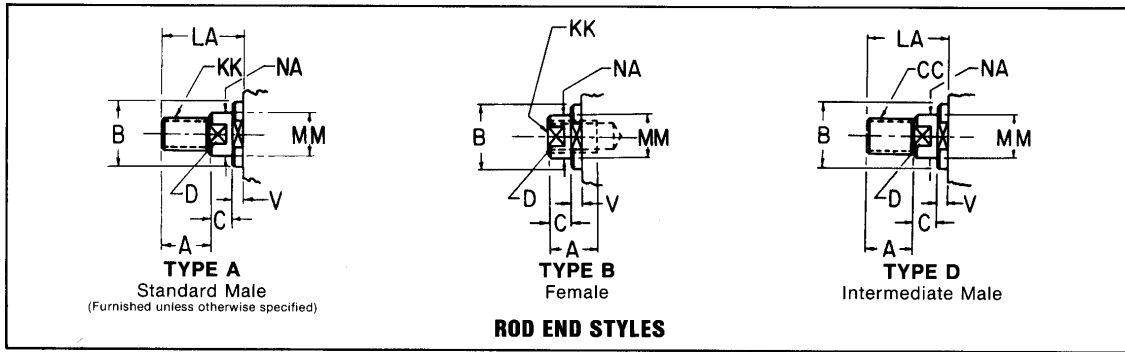

DIMENSIONS AFFECTED BY ROD DIAMETER

BORE	ROD DIA. MM	THREAD SIZE		ROD EXTENSIONS & PILOT DIMENSIONS							ENVELOPE DIMENSIONS				
		KK STD.	CC	A	B +.000/-0.002	C	D	LA	NA	V	RD	W	WF	Y	ZB ADD STROKE
1 1/2	5/8	7/16-20	1/2-20	3/4	1.124	3/8	1/2	1 3/8	9/16	1/4	2.38	5/8	1	2	6
	1*	3/4-16	7/8-14	1 1/8	1.499	1/2	7/8	2 1/8	15/16	1/2	2.5 SQ	1	1 3/8	2 3/8	6 3/8
2	1	3/4-16	7/8-14	1 1/8	1.499	1/2	7/8	1 7/8	15/16	1/4	2.87	3/4	1 3/8	2 3/8	6 7/16
	1 3/8*	1-14	1 1/4-12	1 5/8	1.499	5/8	1 1/8	2 5/8	1 5/16	3/8	3.0 SQ	1	1 5/8	2 5/8	6 11/16
2 1/2	1	3/4-16	7/8-14	1 1/8	1.499	1/2	7/8	1 7/8	15/16	1/4	2.87	3/4	1 3/8	2 3/8	6 9/16
	1 3/8	1-14	1 1/4-12	1 5/8	1.999	5/8	1 1/8	2 5/8	1 5/16	3/8	3.37	1	1 5/8	2 5/8	6 13/16
	1 3/4*	1 1/4-12	1 1/2-12	2	2.374	3/4	1 1/2	3 1/4	1 11/16	1/2	3.5 SQ	1 1/4	1 7/8	2 7/8	7 1/16
3 1/4	1 3/8	1-14	1 1/4-12	1 5/8	1.999	5/8	1 1/8	2 1/2	1 5/16	1/4	3.37	7/8	1 5/8	2 3/4	7 11/16
	1 3/4	1 1/4-12	1 1/2-12	2	2.374	3/4	1 1/2	3 1/8	1 11/16	3/8	4.00	1 1/8	1 7/8	3	7 15/16
	2	1 1/2-12	1 3/4-12	2 1/4	2.624	7/8	1 11/16	3 1/2	1 15/16	3/8	4.25	1 1/4	2	3 1/8	8 1/16
4	1 3/4	1 1/4-12	1 1/2-12	2	2.374	3/4	1 1/2	3	1 11/16	1/4	4.00	1	1 7/8	3	8 3/16
	2	1 1/2-12	1 3/4-12	2 1/4	2.624	7/8	1 11/16	3 3/8	1 15/16	1/4	4.25	1 1/8	2	3 1/8	8 5/16
	2 1/2	1 7/8-12	2 1/4-12	3	3.124	1	2 1/16	4 3/8	2 7/16	3/8	4.50	1 3/8	2 1/4	3 3/8	8 9/16
5	2	1 1/2-12	1 3/4-12	2 1/4	2.624	7/8	1 11/16	3 3/8	1 15/16	1/4	4.25	1 1/8	2	3 1/8	9
	2 1/2	1 7/8-12	2 1/4-12	3	3.124	1	2 1/16	4 3/8	2 7/16	3/8	4.50	1 3/8	2 1/4	3 3/8	9 1/4
	3	2 1/4-12	2 3/4-12	3 1/2	3.749	1	2 5/8	4 7/8	2 15/16	3/8	5.50	1 3/8	2 1/4	3 3/8	9 1/4
	3 1/2	2 1/2-12	3 1/4-12	3 1/2	4.249	1	3	4 7/8	3 7/16	3/8	5.75	1 3/8	2 1/4	3 3/8	9 1/4
6	2 1/2	1 7/8-12	2 1/4-12	3	3.124	1	2 1/16	4 1/4	2 7/16	1/4	4.50	1 1/4	2 1/4	3 1/2	10 1/2
	3	2 1/4-12	2 3/4-12	3 1/2	3.749	1	2 5/8	4 3/4	2 15/16	1/4	5.50	1 1/4	2 1/4	3 1/2	10 1/2
	3 1/2	2 1/2-12	3 1/4-12	3 1/2	4.249	1	3	4 3/4	3 7/16	1/4	5.75	1 1/4	2 1/4	3 1/2	10 1/2
	4	3-12	3 3/4-12	4	4.749	1	3 3/8	5 1/4	3 15/16	1/4	6.50	1 1/4	2 1/4	3 1/2	10 1/2
7	3	2 1/4-12	2 3/4-12	3 1/2	3.749	1	2 5/8	4 3/4	2 7/8	1/4	5.50	1 1/4	2 1/4	3 13/16	11 3/4
	3 1/2	2 1/2-12	3 1/4-12	3 1/2	4.249	1	3	4 3/4	3 3/8	1/4	5.75	1 1/4	2 1/4	3 13/16	11 3/4
	4	3-12	3 3/4-12	4	4.749	1	3 3/8	5 1/4	3 7/8	1/4	6.50	1 1/4	2 1/4	3 13/16	11 3/4
	5	3 1/2-12	4 3/4-12	5	5.749	1	4 1/4	6 1/4	4 7/8	1/4	7.50	1 1/4	2 1/4	3 13/16	11 3/4
8	3 1/2	2 1/2-12	3 1/4-12	3 1/2	4.249	1	3	4 3/4	3 3/8	1/4	5.75	1 1/4	2 1/4	3 15/16	12 13/16
	4	3-12	3 3/4-12	4	4.749	1	3 3/8	5 1/4	3 7/8	1/4	6.50	1 1/4	2 1/4	3 15/16	12 13/16
	5	3 1/2-12	4 3/4-12	5	5.749	1	4 1/4	6 1/4	4 7/8	1/4	7.50	1 1/4	2 1/4	3 15/16	12 13/16
	5 1/2	4-12	5 1/4-12	5 1/2	6.249	1	4 5/8	6 3/4	5 3/8	1/4	8.50	1 1/4	2 1/4	3 15/16	12 13/16

*Rod end cushions available only as non-adjustable type- Consult Lehigh